

Standard Series

LFP12110

12V110Ah

FirstPower®

Dimension

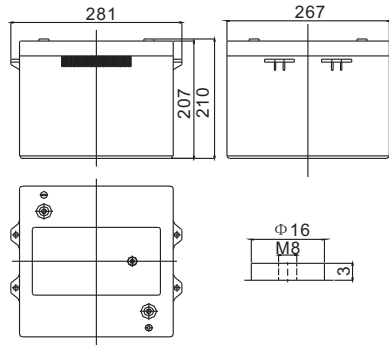

T11
Terminal

Specification

Nominal Voltage		12 V
Capacity(10HR, 25°C)		110 Ah
Dimension	Length	281mm (11.1inch)
	Width	267mm (10.5inch)
	Height	207mm (8.1inch)
	Total Height	210mm (8.3inch)
Approx. Weight		34.0kg (75.0lbs)

Characteristics

Capacity 20°C (68□) To 1.70V/Cell	20 hour rate	116.2Ah
	10 hour rate	110Ah
	5 hour rate	99Ah
	1 hour rate	66.5Ah
	15 min rate	43.5Ah
Internal resistance(Fully charged, 25°C)		Approx. 4m Ω
Capacity affected by temperature (10HR)	40°C	102%
	25°C	100%
	0°C	85%
	-15°C	65%
Self-discharge (25°C)	3 month	Remaining Capacity: 91%
	6 month	Remaining Capacity: 82%
	12 month	Remaining Capacity: 65%
Nominal operating temperature		25°C ±3°C(77°F ±5°F)
Operating temperature range		-15°C~50°C(5°F~122°F)
Float charging voltage(25°C)		13.50 to 13.80V
Cyclic charging voltage(25°C)		14.50 to 14.90V
Maximum charging current		33A
Terminal material		Copper
Maximum discharge current		880A(5 Sec.)

The Relationship for Open Circuit Voltage and Residual Capacity (25°C)

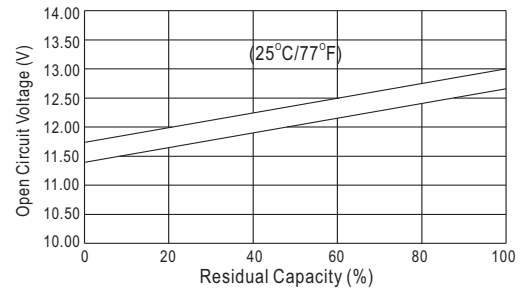

Charging Characteristics(25°C)

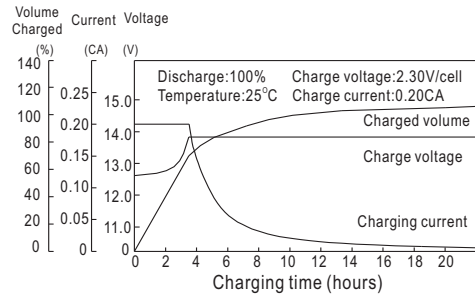

Cycle Life(25°C)

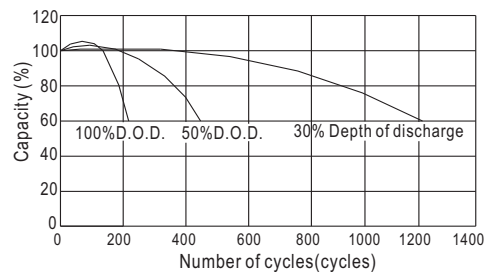

Constant Current Discharge Characteristics (A, 25°C)

F.V/TIME	5min	10min	15min	30min	60min	3h	5h	10h	20h
9.60V	347	231	182	114	69.3	28.5	20.1	11.2	5.86
10.2V	329	219	174	110	66.5	28.1	19.8	11.1	5.81
10.8V	309	206	166	104	63.2	27.5	19.4	11.0	5.78

Constant Power Discharge Characteristics (Watt, 25°C)

5min	10min	15min	30min	60min	3h	5h	10h	20h
3638	2495	1993	1284	790	335	238	133	70.3
3456	2370	1913	1232	758	330	234	132	69.7
3249	2228	1817	1171	720	323	229	132	69.3