

# Standard Series LFP1234 12V34Ah

**FirstPower®**

## Dimension

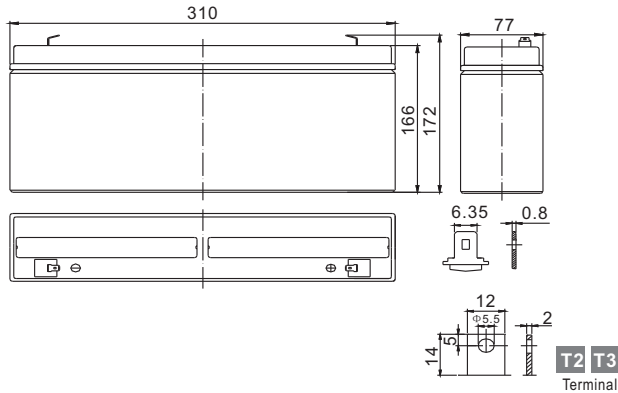

## Specification

Nominal Voltage		12 V
Capacity(10HR, 25°C)		34Ah
Dimension	Length	310mm (12.2inch)
	Width	77mm (3.0inch)
	Height	166mm (6.5inch)
	Total Height(T2/T3)	172mm (6.8inch)/180mm (7.1inch)
Approx. Weight		11kg (24.3lbs)

## Characteristics

Capacity 20°C (68°F) To 1.70V/Cell	20 hour rate	36Ah
	10 hour rate	34Ah
	5 hour rate	30.6Ah
	1 hour rate	20.6Ah
	15 min rate	/
Internal resistance(Fully charged, 25°C)		Approx. 10m Ω
Capacity affected by temperature (10HR)	40°C	102%
	25°C	100%
	0°C	85%
	-15°C	65%
Self-discharge (25°C)	3 month	Remaining Capacity: 91%
	6 month	Remaining Capacity: 82%
	12 month	Remaining Capacity: 65%
Nominal operating temperature		25°C ±3°C(77°F ±5°F)
Operating temperature range		-15°C~50°C(5°F~122°F)
Float charging voltage(25°C)		13.50 to 13.80V
Cyclic charging voltage(25°C)		14.50 to 14.90V
Maximum charging current		10.2A
Terminal material		Copper
Maximum discharge current		340A(5 Sec.)

## The Relationship for Open Circuit Voltage and Residual Capacity (25°C)

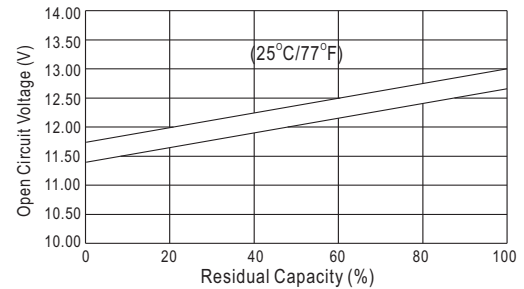

## Charging Characteristics(25°C)

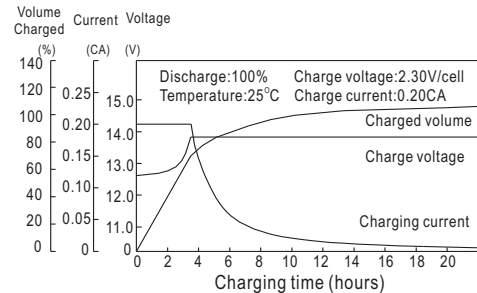

## Cycle Life(25°C)

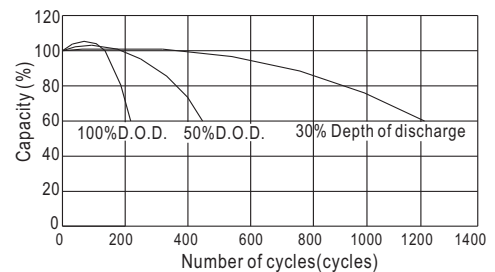

## Constant Current Discharge Characteristics (A, 25°C)

F.V/TIME	5min	10min	15min	30min	60min	3h	5h	10h	20h
9.60V	--	--	--	35.4	21.4	8.80	6.21	3.45	1.81
10.2V	--	--	--	33.9	20.6	8.67	6.12	3.42	1.80
10.8V	--	--	--	32.2	19.5	8.50	6.00	3.40	1.79

## Constant Power Discharge Characteristics (Watt, 25°C)

	5min	10min	15min	30min	60min	3h	5h	10h	20h
	--	--	--	397	244	103	73.4	41.2	21.7
	--	--	--	381	234	102	72.3	40.8	21.5
	--	--	--	362	223	100	70.9	40.8	21.4