

Standard Series LFP1250 12V50Ah

FirstPower®

Dimension

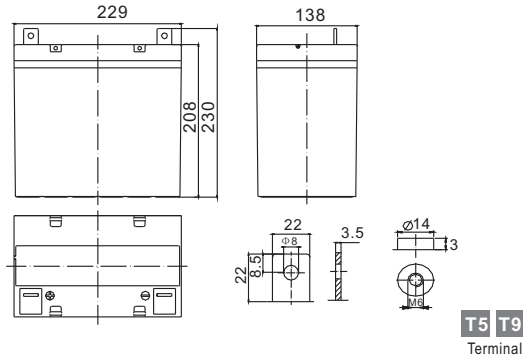

Specification

Nominal Voltage		12 V
Capacity(10HR, 25°C)		50Ah
Dimension	Length	229mm (9.0inch)
	Width	138mm (5.4inch)
	Height	208mm (8.2inch)
	Total Height(T5/T9)	230mm (9.1inch)/211mm (8.3inch)
Approx. Weight		16.5kg (36.4lbs)

Characteristics

Capacity 20°C (68°F) To 1.70V/Cell	20 hour rate	52.4Ah
	10 hour rate	50Ah
	5 hour rate	45Ah
	1 hour rate	31.7Ah
	15 min rate	21.0Ah
Internal resistance(Fully charged, 25°C)		Approx. 6.2m Ω
Capacity affected by temperature (10HR)	40°C	102%
	25°C	100%
	0°C	85%
	-15°C	65%
Self-discharge (25°C)	3 month	Remaining Capacity: 91%
	6 month	Remaining Capacity: 82%
	12 month	Remaining Capacity: 65%
Nominal operating temperature		25°C ±3°C(77°F ±5°F)
Operating temperature range		-15°C~50°C(5°F~122°F)
Float charging voltage(25°C)		13.50 to 13.80V
Cyclic charging voltage(25°C)		14.50 to 14.90V
Maximum charging current		15A
Terminal material		Copper
Maximum discharge current		500A(5 Sec.)

The Relationship for Open Circuit Voltage and Residual Capacity (25°C)

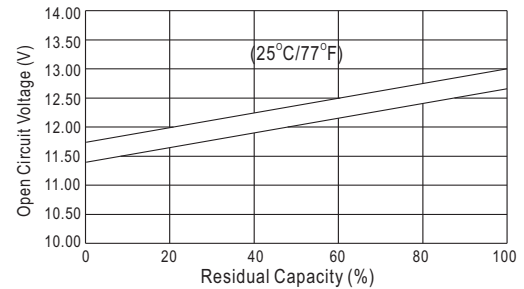

Charging Characteristics(25°C)

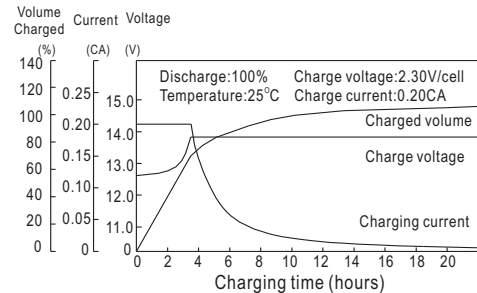

Cycle Life(25°C)

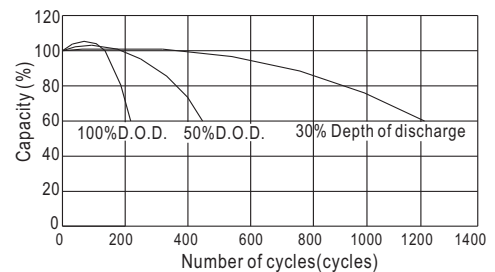

Constant Current Discharge Characteristics (A, 25°C)

F.V/TIME	5min	10min	15min	30min	60min	3h	5h	10h	20h
9.60V	160	110	88.0	54.0	33.0	12.7	9.14	5.08	2.64
10.2V	152	105	84.5	51.8	31.7	12.5	9.00	5.03	2.62
10.8V	143	98.2	80.3	49.2	30.1	12.3	8.82	5.00	2.60

Constant Power Discharge Characteristics (Watt, 25°C)

	5min	10min	15min	30min	60min	3h	5h	10h	20h
	1680	1188	966	606	376	149	108	60.6	31.7
	1596	1129	928	582	361	147	106	60.1	31.4
	1500	1061	881	553	343	144	104	60.1	31.2