

# Standard Series

# LFP1278

12V78Ah

**FirstPower®**

## Dimension

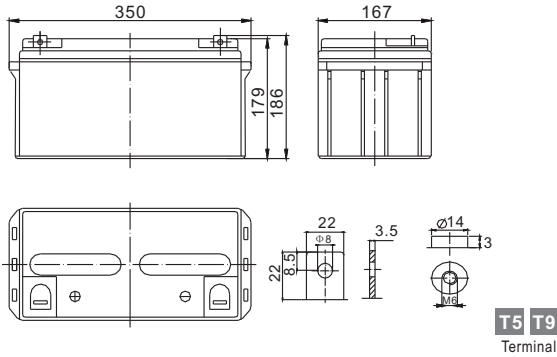

## Specification

Nominal Voltage		12 V
Capacity(10HR, 25°C)		78 Ah
Dimension	Length	350mm (13.8inch)
	Width	167mm (6.6inch)
	Height	179mm (7.0inch)
	Total Height(T5/T9)	186mm (7.3inch)/179mm (7.1inch)
Approx. Weight		23.5kg (51.8lbs)

## Characteristics

Capacity 20°C (68□) To 1.70V/Cell	20 hour rate	82.4Ah
	10 hour rate	78Ah
	5 hour rate	70Ah
	1 hour rate	47.2Ah
	15 min rate	31Ah
Internal resistance(Fully charged, 25°C)		Approx.5.5m Ω
Capacity affected by temperature (10HR)	40°C	102%
	25°C	100%
	0°C	85%
	-15°C	65%
Self-discharge (25°C)	3 month	Remaining Capacity: 91%
	6 month	Remaining Capacity: 82%
	12 month	Remaining Capacity: 65%
Nominal operating temperature		25°C ±3°C(77°F ±5°F)
Operating temperature range		-15°C~50°C(5°F~122°F)
Float charging voltage(25°C)		13.50 to 13.80V
Cyclic charging voltage(25°C)		14.50 to 14.90V
Maximum charging current		23.4A
Terminal material		Copper
Maximum discharge current		750A(5 Sec.)

## The Relationship for Open Circuit Voltage and Residual Capacity (25°C)

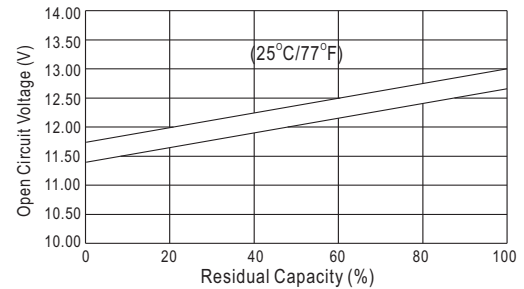

## Charging Characteristics(25°C)

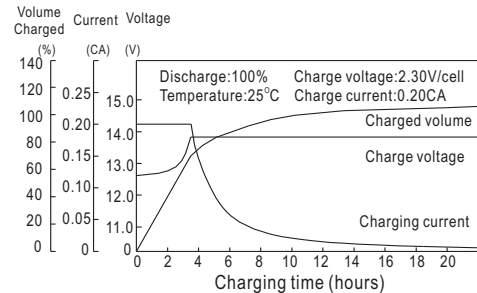

## Cycle Life(25°C)

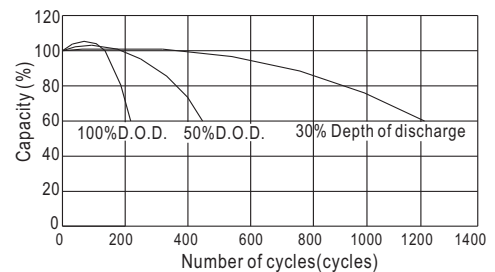

## Constant Current Discharge Characteristics (A, 25°C)

F.V/TIME	5min	10min	15min	30min	60min	3h	5h	10h	20h
9.60V	246	164	129	81.1	49.1	20.2	14.3	7.92	4.16
10.2V	233	156	124	77.9	47.2	19.9	14.0	7.85	4.12
10.8V	219	146	117	74.0	44.8	19.5	13.8	7.80	4.10

## Constant Power Discharge Characteristics (Watt, 25°C)

5min	10min	15min	30min	60min	3h	5h	10h	20h
2580	1769	1413	910	560	237	168	94.5	49.9
2451	1681	1357	874	538	234	166	93.7	49.4
2304	1580	1289	830	511	229	163	93.7	49.1