

# Standard Series LFP1280 12V80Ah

**FirstPower®**

## Dimension

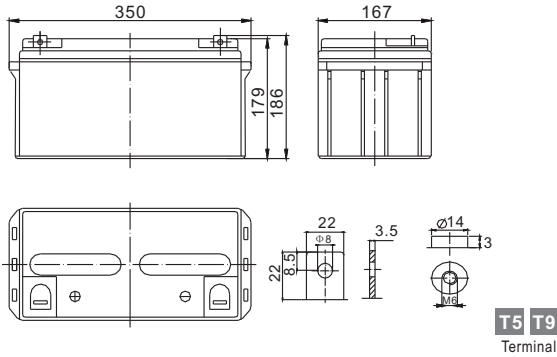

## Specification

Nominal Voltage		12 V
Capacity(10HR, 25°C)		80Ah
Dimension	Length	350mm (13.8inch)
	Width	167mm (6.6inch)
	Height	179mm (7.0inch)
	Total Height(T5/T9)	186mm (7.3inch)/179mm (7.1inch)
Approx. Weight		24.0kg (52.9lbs)

## Characteristics

Capacity 20°C (68□) To 1.70V/Cell	20 hour rate	84.6Ah
	10 hour rate	80Ah
	5 hour rate	72Ah
	1 hour rate	49.9Ah
	15 min rate	32.5Ah
Internal resistance(Fully charged, 25°C)		Approx.5.4m Ω
Capacity affected by temperature (10HR)	40°C	102%
	25°C	100%
	0°C	85%
	-15°C	65%
Self-discharge (25°C)	3 month	Remaining Capacity: 91%
	6 month	Remaining Capacity: 82%
	12 month	Remaining Capacity: 65%
Nominal operating temperature		25°C ±3°C(77°F ±5°F)
Operating temperature range		-15°C~50°C(5°F~122°F)
Float charging voltage(25°C)		13.50 to 13.80V
Cyclic charging voltage(25°C)		14.50 to 14.90V
Maximum charging current		24A
Terminal material		Copper
Maximum discharge current		800A(5 Sec.)

## The Relationship for Open Circuit Voltage and Residual Capacity (25°C)

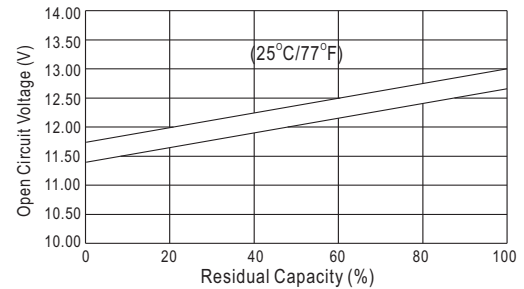

## Charging Characteristics(25°C)

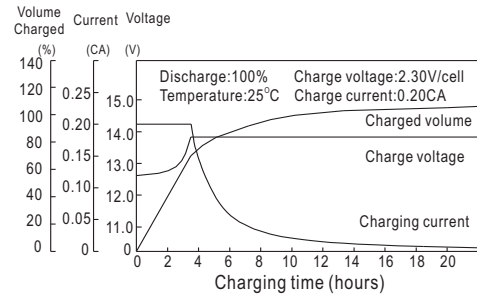

## Cycle Life(25°C)

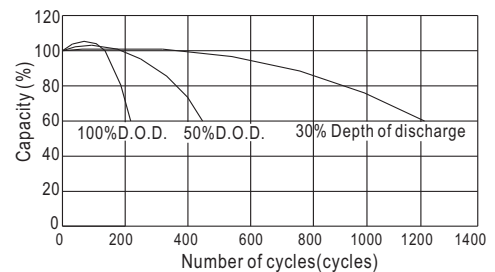

## Constant Current Discharge Characteristics (A, 25°C)

F.V/TIME	5min	10min	15min	30min	60min	3h	5h	10h	20h
9.60V	256	175	135	84.0	52.0	20.3	14.6	8.12	4.26
10.2V	243	166	130	80.6	49.9	20.0	14.4	8.08	4.23
10.8V	229	156	123	76.6	47.4	19.6	14.1	8.00	4.20

## Constant Power Discharge Characteristics (Watt, 25°C)

	5min	10min	15min	30min	60min	3h	5h	10h	20h
2688	1890	1482	942	593	239	173	97.0	51.1	
2554	1796	1423	905	569	235	170	96.5	50.8	
2400	1688	1352	860	541	230	167	95.5	50.4	